

**SUPER GRAPHIC
and
SUPER SPEED GRAPHIC[®]**

**SERVICE INSTRUCTIONS
and
PARTS CATALOG**

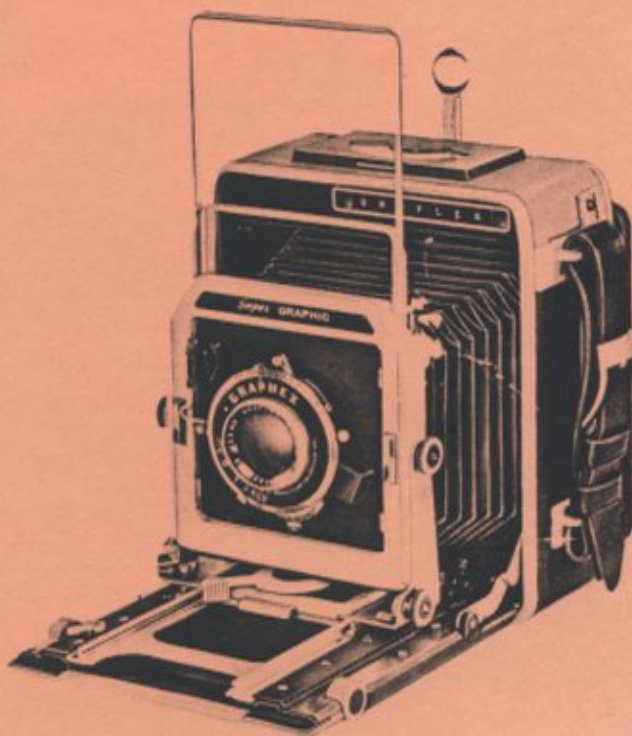
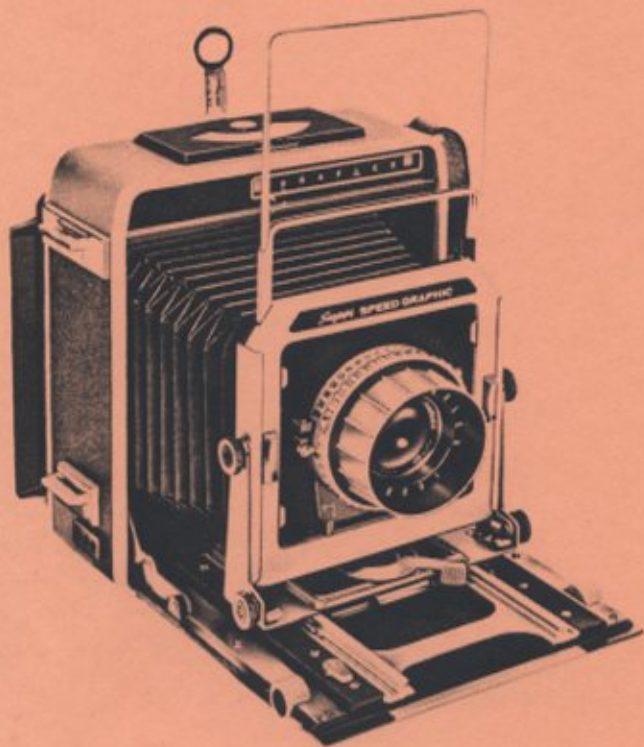

TABLE OF CONTENTS

<u>Paragraph</u>		<u>Page</u>
	Introduction.	1
A	Camera Complete.	1
B	Optical Measurement of Lens Travel.	1
C	Rangefinder.	2
D	Rangefinder Operation.	3
E	Rangefinder Infinity	3
F	Double Image Adjustment.	3
G	Actuating Bracket Adjustment.	3
H	Rangefinder and Lens Synchronization	3
J	Multiple Lens Fitting	4
K	Rangefinder Housing Exchange	4
L	Rangefinder Trouble Shooting Chart.	4
M	Service Equipment	5
N	Super Graphic Analyzer - General.	5
P	Super Graphic Analyzer - Materials	6
Q	Super Graphic Analyzer - Calibration	11
R	Super Graphic Analyzer Camera Test	12
S	Camera Basic - Disassembly and Reassembly.	17
T	Focusing Frame Assembly - Disassembly and Reassembly . .	19
U	Front Standard Complete - Disassembly and Reassembly . . .	21
V	Rangefinder Housing Complete - Disassembly and Reassembly	22
W	Bed Complete - Disassembly and Reassembly	25
X	Back Assembly - Disassembly and Reassembly	26

Figure

	Parts List Introduction	29
1	Camera Complete - Super Graphic	30
1A	Camera Complete - Super Speed Graphic	30
2	Camera Basic (Cameras bearing serial no. over 646124) . . .	32
3	Focusing Frame Assembly.	35
4	Front Standard Complete (Cameras bearing serial no. over 646124)	36
5	Rangefinder Housing Complete (Cameras bearing serial no. over 646124)	41
6	Bed Complete	46
7	Back Assembly	48
8	Body Complete (Cameras bearing serial no. over 646124) . . .	52
9	Camera Basic (Cameras bearing serial no. up to 646124) . . .	54
10	Front Standard Complete (Cameras bearing serial no. up to 646124)	57
11	Rangefinder Housing Complete (Cameras bearing serial no. up to 646124)	59
12	Body Complete (Cameras bearing serial no. up to 646124) . . .	62

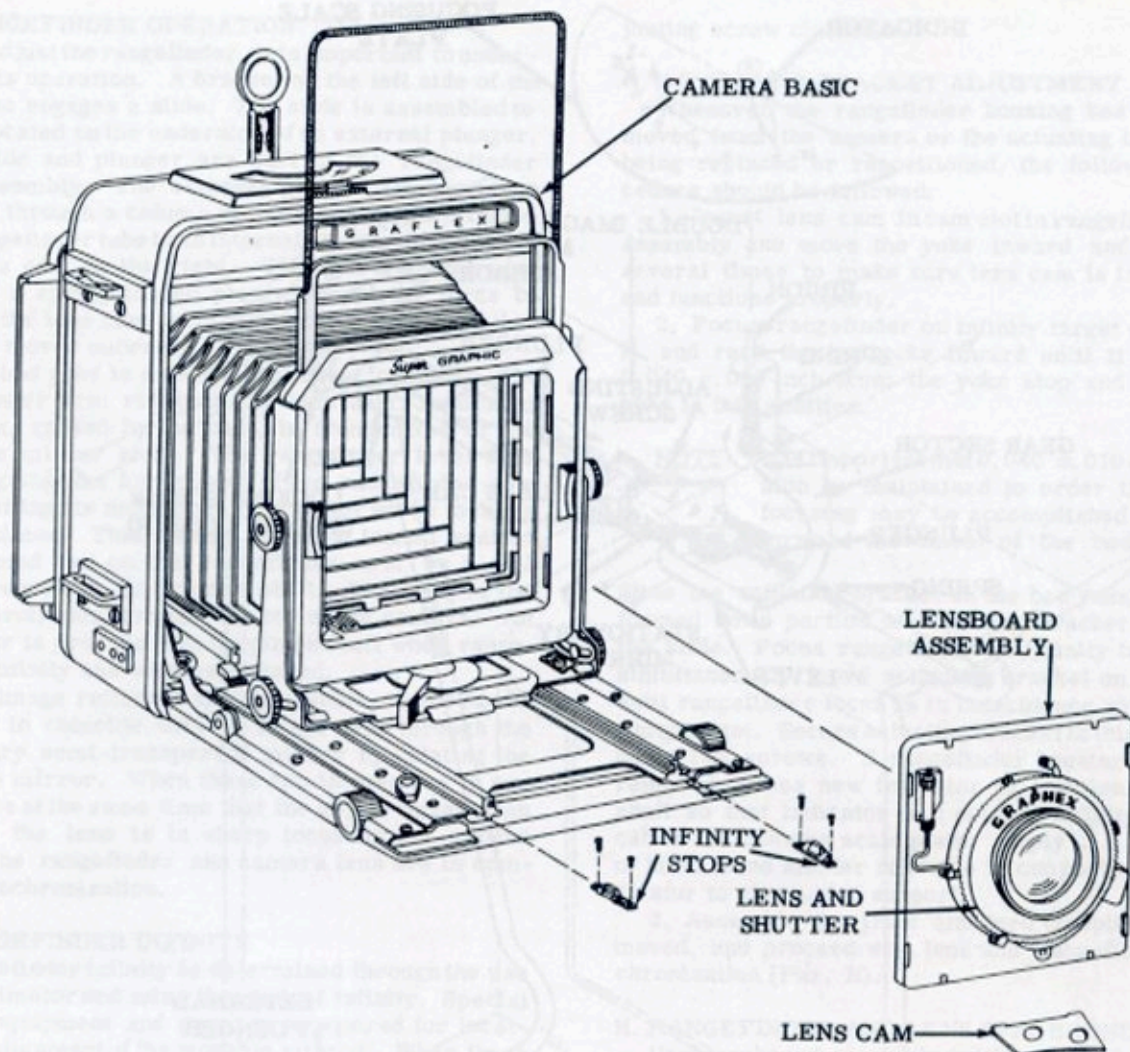

Figure 1. CAMERA COMPLETE

INTRODUCTION

This section on the Graflex Service Parts Manual covers the Service Instructions and Parts List for the Super Graphic and Super Speed Graphic Cameras. The text and illustrations are based on the Super Graphic Camera. The differences between the Super Graphic and the Super Speed Graphic are clearly described in the Parts List.

A. CAMERA COMPLETE

The Super Graphic Camera (Figure 1) includes a camera basic, standard shutter (with lens) mounted in a Super Graphic Lensboard Assembly, matching lens cam and a set of infinity stops to match the focal length of the lens.

The Super Speed Graphic Camera is identical to the Super Graphic except, the Super Speed Graphic is equipped with a Graflex 1000 Shutter. The Graflex 1000 Shutter does not require a lensboard for mounting.

NOTE: The lens cam is selected after the lens has been optically measured for actual focal length (lens travel).

B. OPTICAL MEASUREMENT OF LENS TRAVEL

Optical measurements are best determined through the use of a collimator with an accurate measuring device. Lens is set up and focused on theoretical infinity and the measuring device set for 0. Lens movement is measured (to nearest .001 of an inch) from infinity to the following near distance:

Lens Focal Length	Near Distance (target to film plane)
3 to 7 inch	4 feet
7 to 15 inch	10 feet

At least three different readings should be taken and recorded to insure that a satisfactory figure has been obtained. If equipment is not available, send lens and shutter to nearest Graflex Service Department for collimation and selection of cam.

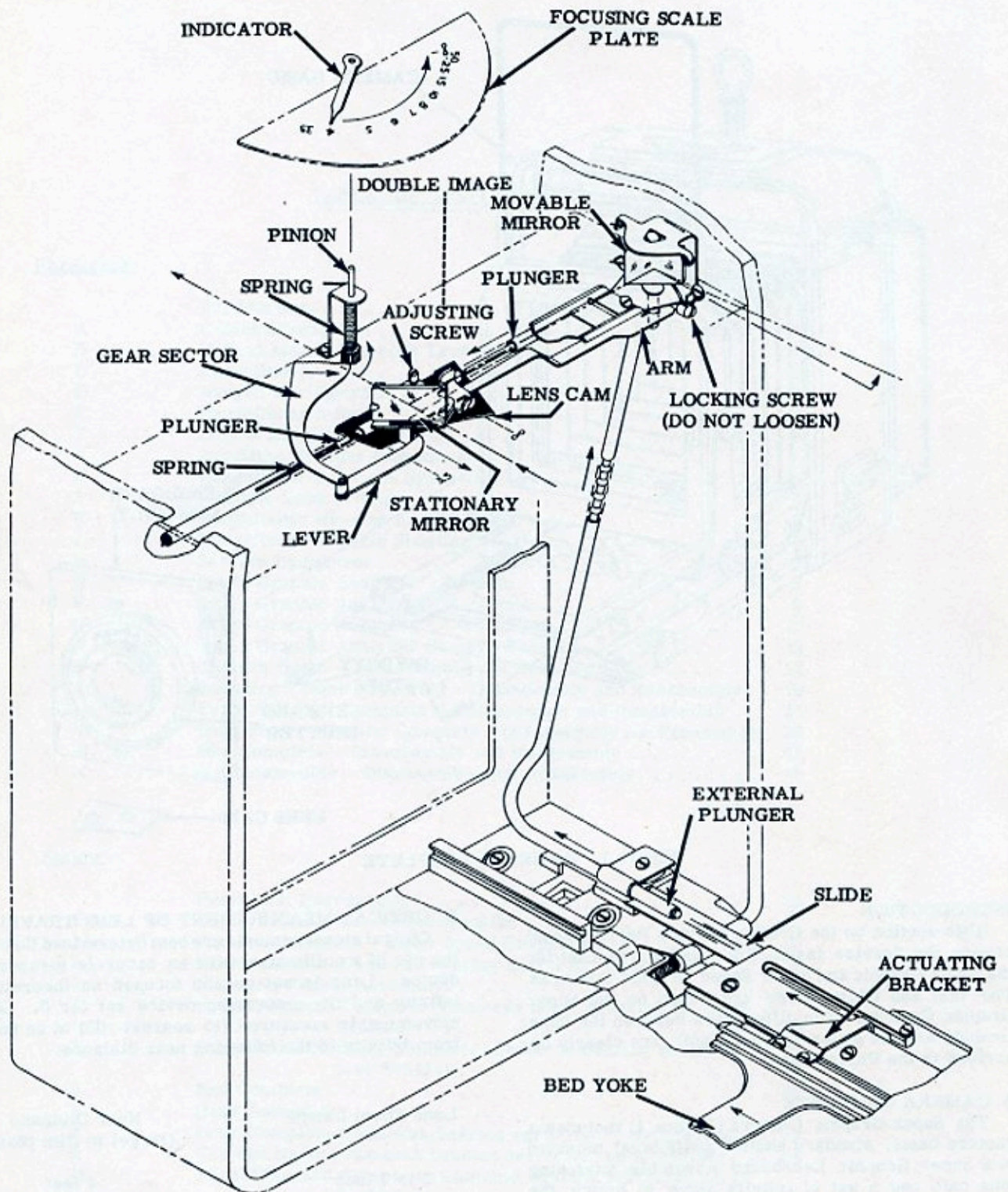

Figure 2. RANGEFINDER OPERATION

C. RANGEFINDER

The rangefinder is mounted in a drawer type housing, located under the top section of the camera. Once the rangefinder is adjusted, it can be used with

a wide variety of lenses through the use of lens cams. Lenses may vary in focal length from wide angle through telephoto.

D. RANGEFINDER OPERATION (Figure 2)

To adjust the rangefinder, it is important to understand its operation. A bracket on the left side of the bed yoke engages a slide. The slide is assembled to a pin located on the underside of an external plunger. The slide and plunger are part of the rangefinder tube assembly. The external plunger transmits its motion through a column of balls and spacers inside the rangefinder tube to an internal plunger that pushes the lens cam to the right. The lens cam presses against a spring loaded plunger supplying force to return the lens cam to its original position when the yoke is moved outward.

The bed yoke is moved in or out for focusing. The rangefinder arm rides on the lens cam; motion of the arm, caused by the cam, is transmitted to the movable mirror shaft. The rangefinder lever also rides against the formed end of the rangefinder arm transmitting its motion to a gear sector which meshes with a pinion. This linkage is spring loaded against the formed end on the rangefinder arm by a coil spring wound to this pinion shaft. The shaft of the pinion protrudes through the top of the camera. An indicator is pressed onto the pinion shaft when rangefinder infinity has been established.

The image reflected off the movable mirror can be brought to coincide with the image seen through the stationary semi-transparent mirror by rotating the movable mirror. When these two images are in coincidence at the same time that the object image seen through the lens is in sharp focus on the ground glass, the rangefinder and camera lens are in complete synchronization.

E. RANGEFINDER INFINITY

Rangefinder infinity is determined through the use of a collimator and using theoretical infinity. Special optical equipment and gages are required for locating and alignment of the movable mirror. When these adjustments have been accomplished, the locking screw on the rangefinder arm is tightened to maintain this fixed infinity setting. This locking screw should not be loosened. See Par. K for rangefinders requiring fixed infinity setting.

F. DOUBLE IMAGE ADJUSTMENT

1. Remove battery cover and batteries.
2. Remove clip and locate the lock spring on roof of battery compartment and swing toward rear of camera. This will release the focusing scale cover assembly.
3. Remove the exposure guide and exposure guide spring. When performing this operation be careful not to bend or twist the focusing scale indicator on the pinion shaft, otherwise it will be necessary to replace the indicator.
4. Remove the lens cam; this in turn will allow the focusing scale indicator to swing clear of the focusing scale plate.
5. Replace the lens cam in slot in rangefinder tube.
6. With a screwdriver, locate slot in adjusting screw (located under hole) in uncovered portion of the camera body. To raise image, turn adjusting screw counterclockwise. To lower image, turn ad-

justing screw clockwise.

G. ACTUATING BRACKET ADJUSTMENT

Whenever the rangefinder housing has been removed from the camera or the actuating bracket is being replaced or repositioned, the following procedure should be followed:

1. Insert lens cam in cam slot in rangefinder tube assembly and move the yoke inward and outward several times to make sure lens cam is in position and functions properly.
2. Focus rangefinder on infinity target over 5000 ft. and rack the bed yoke inward until it is within $0.040 \pm .010$ inch from the yoke stop and lock bed yoke in this position.

NOTE: It is important that $0.040 \pm .010$ dimension be maintained in order that all focusing may be accomplished with a forward movement of the bed yoke.

Slide the actuating bracket on the bed yoke until the formed down portion of actuating bracket engages the slide. Focus rangefinder on infinity target and simultaneously move actuating bracket on bed yoke until rangefinder focus is in coincidence with the infinity target. Secure actuating bracket in this position using two screws. If rangefinder housing has been removed, press new indicator in position on pinion shaft so that indicator will point to infinity (∞) location on focusing scale plate. Apply small amount of M373 Bond Master adhesive in cup portion of indicator to give added support.

3. Assemble the front standard complete, if removed, and proceed with lens and rangefinder synchronization (Par. H).

H. RANGEFINDER AND LENS SYNCHRONIZATION

Use lensboard assembly (with lens) and lens cam which were originally fitted to the camera and proceed as follows:

1. Rack bed yoke outward and install lens cam in cam slot in rangefinder tube. Rack bed yoke inward and outward several times, making sure that cam is in position and functions properly.
2. Focus rangefinder on infinity target over 5000 ft. and check rangefinder infinity focus. Lock bed yoke in this position. The indicator on top of camera should point to infinity (∞) position on focusing scale plate. If necessary, make double image adjustment.
3. Position lensboard assembly (with lens) in front standard making sure lensboard is square in front frame and securely locked in place.
4. Pull front standard out to existing infinity stops and lock front standard in this position. Use a square to check squareness of front standard on bed yoke. Adjust if necessary.
5. Check ground glass focus of lens, using same target as in 2 above. If rangefinder and lens focus coincide; unlock bed yoke and rack forward to near distance of the lens used, lock bed yoke in this position and recheck coincidence. If in coincidence, proper rangefinder and lens are in complete synchronization.

J. MULTIPLE LENS FITTING

Before additional lenses are fitted to the camera, it must be determined if original lensboard assembly (with lens) is in synchronization with the rangefinder.

1. Repeat Rangefinder and lens synchronization (Par. H).
2. Rack bed yoke outward and remove original lens cam and lensboard assembly (with lens) and insert lens cam for new lens to be fitted. Rack bed yoke inward and outward several times, making sure cam is in position and functions properly.
3. Rack bed yoke inward to infinity position of the rangefinder and lock bed yoke in this position. The indicator will point to infinity (∞) position on focusing scale plate.
4. Position new lensboard assembly (with lens) in front standard making sure lensboard is square and securely locked in place.
5. Tip down infinity stops (original) to permit free movement of the front standard on the bed yoke.
6. Focus new lens on infinity target over 5000 ft. and move front standard so that lens focuses a sharp infinity target on ground glass and lock front standard in this position. Use a square to check the

squareness of front standard on bed yoke. Assemble two additional infinity stops in position.

7. Check ground glass focus of lens, using same target as in 6 above. If rangefinder and lens focus coincide, unlock bed yoke and rack forward to near distance of the lens used, lock bed yoke in this position and recheck coincidence. If in coincidence; proper rangefinder and new lens are in complete synchronization.

K. RANGEFINDER HOUSING EXCHANGE

Whenever the fixed infinity setting of the rangefinder needs to be established, it is recommended that the rangefinder housing assembly be removed from the camera and returned to the nearest Graflex Service Department. An alternate factory reconditioned rangefinder housing assembly will be returned (nominal charge) with rangefinder infinity and lever adjustments accomplished and ready for installation. See Par. S. 1. a thru j for removal of the rangefinder housing assembly.

L. RANGEFINDER TROUBLE SHOOTING CHART

The following table of potential troubles, causes and remedies, is supplied to expedite service of common difficulties.

NOTE: Repairs that involve the removal of the rangefinder housing assembly from the camera or an adjustment to the rangefinder actuating bracket, refer to Par. G.

TRouble	CAUSE	REMEDY
Indicator does not locate on infinity (∞) position on focusing scale plate.	Indicator loose on pinion shaft. Gear Sector loose on its shaft. Broken pinion spring, worn teeth on pinion or gear sector.	Replace. Replace. Replace.
With yoke racked all the way back, rangefinder will not come into coincidence at infinity.	Actuating bracket has shifted forward or is bent.	Adjust or replace. (see paragraph G)
Double image.	Stationary mirror out of height adjustment with movable mirror.	Adjust. (see paragraph F)
No superimposed image on stationary mirror.	Movable mirror broken, fallen off, or movable mirror shaft is out of position thus causing fixed infinity setting of rangefinder to be out of adjustment.	(see paragraph K)
Movable image travel is in diagonal direction instead of horizontal.	Springs supporting movable mirror shaft in position in V slot have become unhooked or broken.	Rehook or replace (providing movable mirror has not shifted and caused fixed infinity setting of rangefinder to be out of adjustment. (see paragraph K)

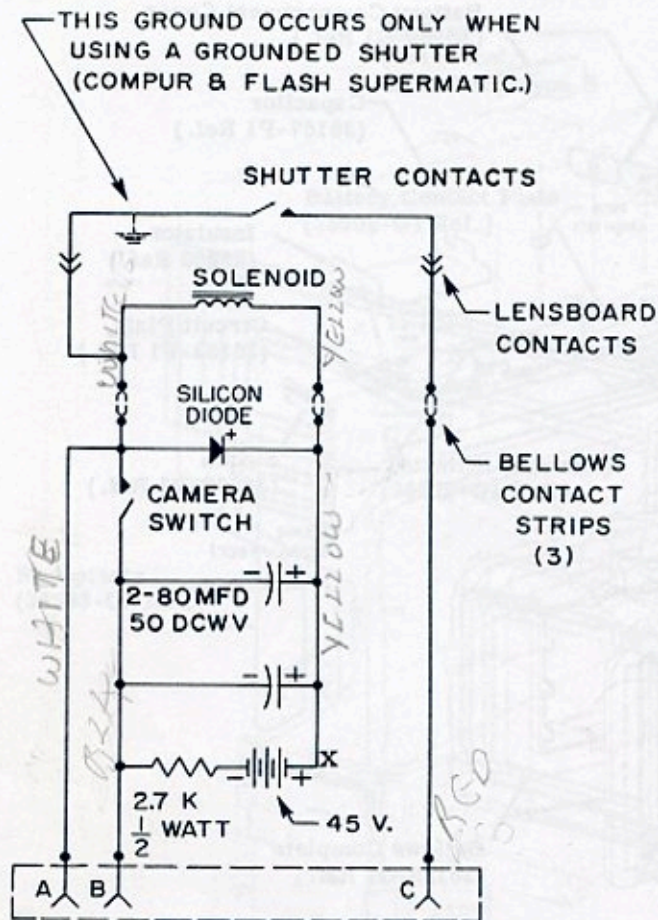

Figure 5. CAMERA CIRCUIT SCHEMATIC

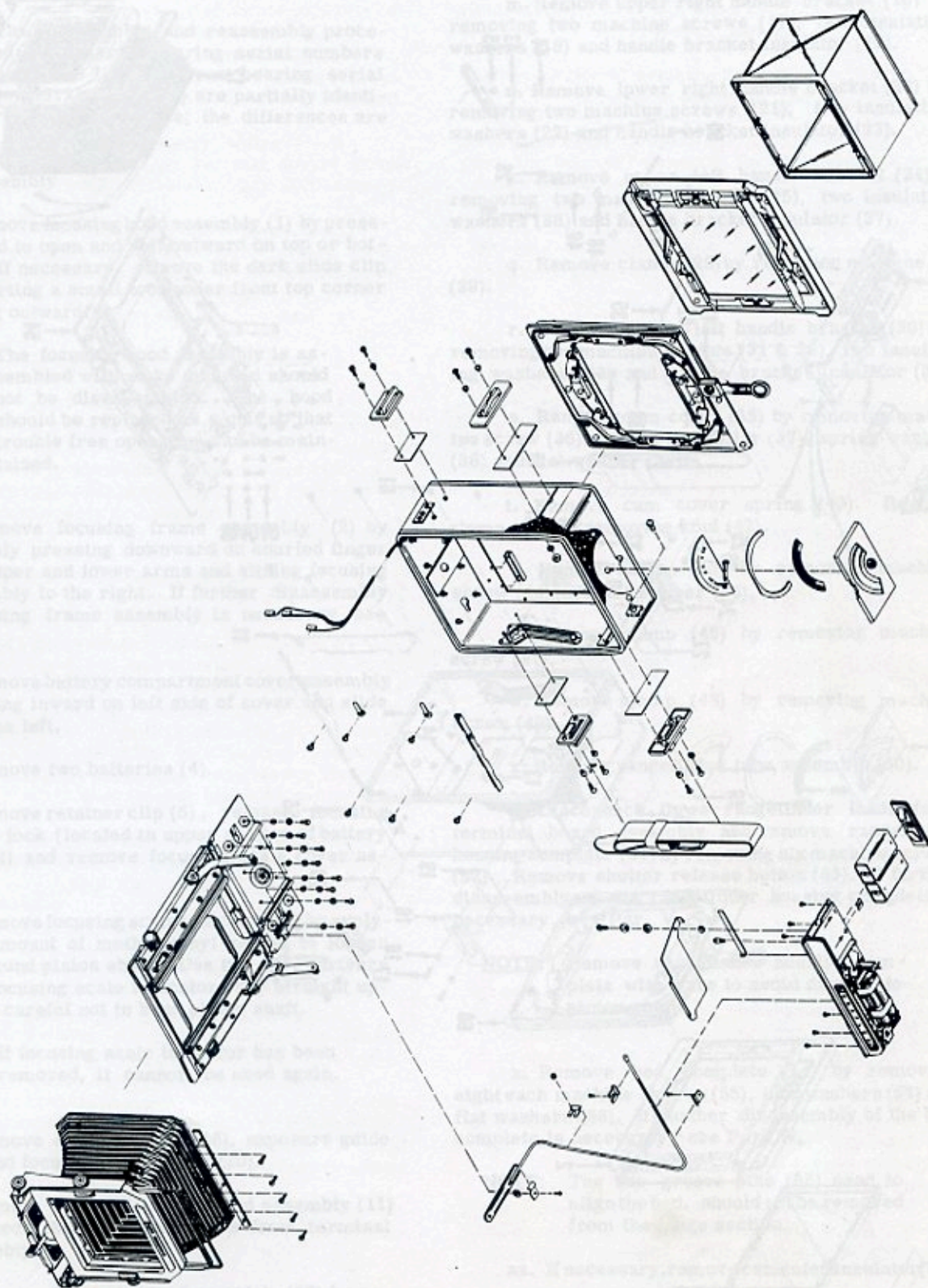

Figure 6. CAMERA BASIC (up to serial No. 646124)

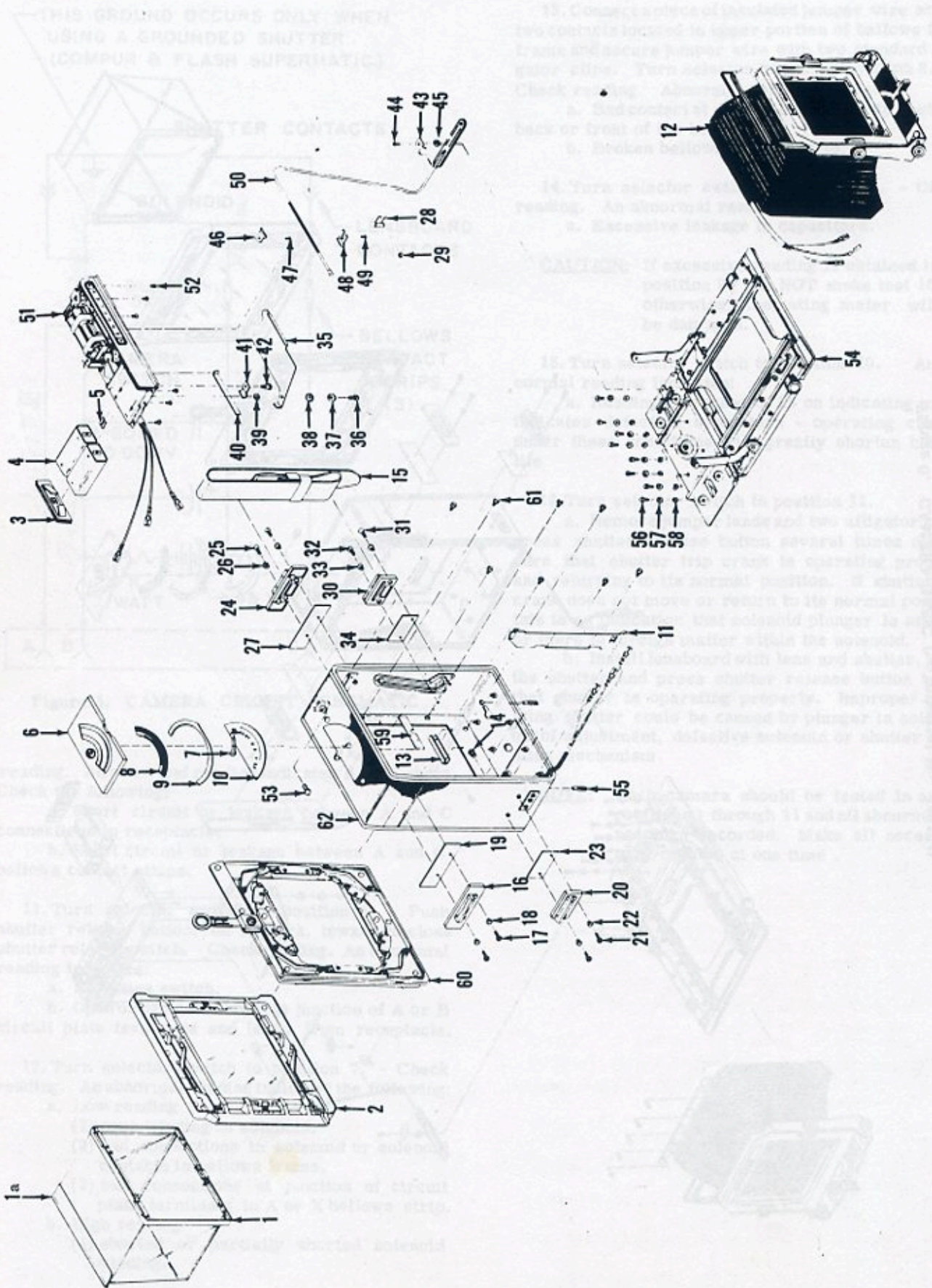

Figure 7. CAMERA BASIC (over serial No. 646124)

S. CAMERA BASIC - DISASSEMBLY
AND REASSEMBLY

GENERAL: The disassembly and reassembly procedure is based on cameras bearing serial numbers over 646124 (Figure 7). Cameras bearing serial numbers up to 646124 (Figure 6) are partially identical in construction and service; the differences are described in the Parts List.

1. Disassembly

a. Remove focusing hood assembly (1) by pressing downward to open and pull outward on top or bottom panel. If necessary, remove the dark slide clip (1a) by inserting a small tool under front top corner and pressing outward.

NOTE: The focusing hood assembly is assembled with stake pins and should not be disassembled. The hood should be replaced as a unit so that trouble free operation can be maintained.

b. Remove focusing frame assembly (2) by simultaneously pressing downward on knurled finger pads of the upper and lower arms and sliding focusing frame assembly to the right. If further disassembly of the focusing frame assembly is necessary, see Par. T.

c. Remove battery compartment cover assembly (3) by pressing inward on left side of cover and slide slightly to the left.

d. Remove two batteries (4).

e. Remove retainer clip (5), release focusing scale cover lock (located in upper section of battery compartment) and remove focusing scale cover assembly (6).

f. Remove focusing scale indicator (7) by applying small amount of methyl ethyl ketone to loosen adhesive around pinion shaft. Use two screwdrivers to support focusing scale indicator, pry straight upward, being careful not to bend pinion shaft.

NOTE: If focusing scale indicator has been removed, it cannot be used again.

g. Remove exposure guide (8), exposure guide spring (9) and focusing scale plate (10).

h. Remove terminal cover board assembly (11) and disconnect three bellows leads from terminal board assembly.

i. Remove front standard complete (12) by removing six bellows clips (13). If further disassembly of the front standard complete is necessary, see Par. U.

j. Remove terminal board cover stud (14).

k. Remove handle (15).

m. Remove upper right handle bracket (16) by removing two machine screws (17), two insulating washers (18) and handle bracket insulator (19).

n. Remove lower right handle bracket (20) by removing two machine screws (21), two insulating washers (22) and handle bracket insulator (23).

p. Remove upper left handle bracket (24) by removing two machine screws (25), two insulating washers (26) and handle bracket insulator (27).

q. Remove clamp (28) by removing machine nut (29).

r. Remove lower left handle bracket (30) by removing two machine screws (31 & 32), two insulating washers (33) and handle bracket insulator (34).

s. Remove cam cover (35) by removing machine screw (36), cam cover collar (37), spring washer (38) and flat washer (39).

t. Remove cam cover spring (40). Remove clamp (41) by removing stud (42).

u. Remove clamp (43) by removing machine screw (44) and flat washer (45).

v. Remove clamp (46) by removing machine screw (47).

w. Remove clamp (48) by removing machine screw (49).

x. Remove rangefinder tube assembly (50).

y. Disconnect three rangefinder leads from terminal board assembly and remove rangefinder housing complete (51) by removing six machine screws (52). Remove shutter release button (53). If further disassembly of the rangefinder housing complete is necessary, see Par. V.

NOTE: Remove rangefinder housing complete with care to avoid damage to pinion shaft.

z. Remove bed complete (54) by removing eight each machine screws (56), lock washers (57) and flat washers (58). If further disassembly of the bed complete is necessary, see Par. W.

NOTE: The two groove pins (55) used to align the bed, should not be removed from the hinge section.

aa. If necessary, remove cemented insulator (59).

bb. Remove back assembly (60) from the body complete (62) by removing eight machine screws (61). If further disassembly of the back assembly is necessary, see Par. X.

2. Reassembly

a. Assemble back assembly (60) to body complete (62), using eight machine screws (61).

b. Apply 3M EC-880 adhesive to bottom surface of insulator (59) and assemble in place.

c. Assemble bed complete (54), using eight each flat washers (58), lock washers (57) and machine screws (56). Check bed alignment and adjust if necessary. If the two groove pins (55) have been removed, drill two additional holes $0.123 + .003 - .000 \times 0.300 + .015 - .000$ deep. Insert two groove pins (55), and press flush to 0.010 below covering on camera body.

d. Assemble shutter release button (53) and position rangefinder housing complete (51) in camera body. Move rangefinder housing forward and backward and simultaneously press shutter release button, until button correctly operates the switch. It may be necessary to use a shorter or longer button. Insert and drive tight, six machine screws (52). Connect three rangefinder leads from terminal board assembly.

e. Position rangefinder tube assembly (50) in camera body.

f. Assemble clamp (48), using machine screw (49).

g. Assemble clamp (46), using machine screw (47).

h. Apply a small amount of Cordo #2055 adhesive to underside (formed portion) of clamp (43). Assemble clamp, using flat washer (45) and machine screw (44). Do not tighten machine screw.

i. Assemble clamp (41), using stud (42). Assemble cam cover spring (40).

j. Assemble cam cover (35), using flat washer (39), spring washer (38), cam cover collar (37) and machine screw (36).

NOTE: The cam cover should not exhibit any looseness when closed and cam spring should keep cam cover in open position for cam changing. Adjust if necessary.

k. Assemble lower left handle bracket (30), using insulator (34), two insulating washers (33), machine screw (32) and machine screw (31).

m. Press rangefinder tube against rear partition and assemble clamp (28) and machine nut (29). Tighten machine screw (44).

n. Assemble upper left handle bracket (24), using handle bracket insulator (27), two insulating washers (26) and two machine screws (25).

p. Assemble lower right handle bracket (20), using handle bracket insulator (23), two insulating washers (22) and two machine screws (21).

q. Assemble upper right handle bracket (16), using handle bracket insulator (19), two insulating washers (18) and two machine screws (17).

r. Assemble handle (15).

s. Assemble terminal board cover stud (14).

t. Connect three bellows leads to terminal board assembly and position bellows portion of front standard complete (12) in camera body and assemble six bellows clips (13). Lubricate two rails and position front portion of front standard in bed yoke. Check sliding locking action of front standard, adjust if necessary.

u. Assemble terminal board cover assembly (11).

v. Assemble focusing scale plate (10), exposure guide spring (9), exposure guide (8) and proceed with actuating bracket adjustment, Par. G, before assembly of focusing scale indicator (7). If necessary, make double vision adjustment, Par. F. Assemble focusing scale cover assembly (6) and lock in place with focusing scale cover lock. Assemble retainer clip (5) between cover lock and camera body.

w. Assemble two batteries (4) in battery compartment. The red positive (+) end on left side and black negative (-) end on right side.

x. Assemble battery compartment cover assembly (3) by pressing inward and slide to the right until locked in place.

y. Assemble focusing frame assembly (2) in position on back assembly.

z. Assemble focusing hood assembly (1).

aa. Check all operations of the camera and make all necessary adjustments. See Super Graphic analyzer camera test, Par. R.

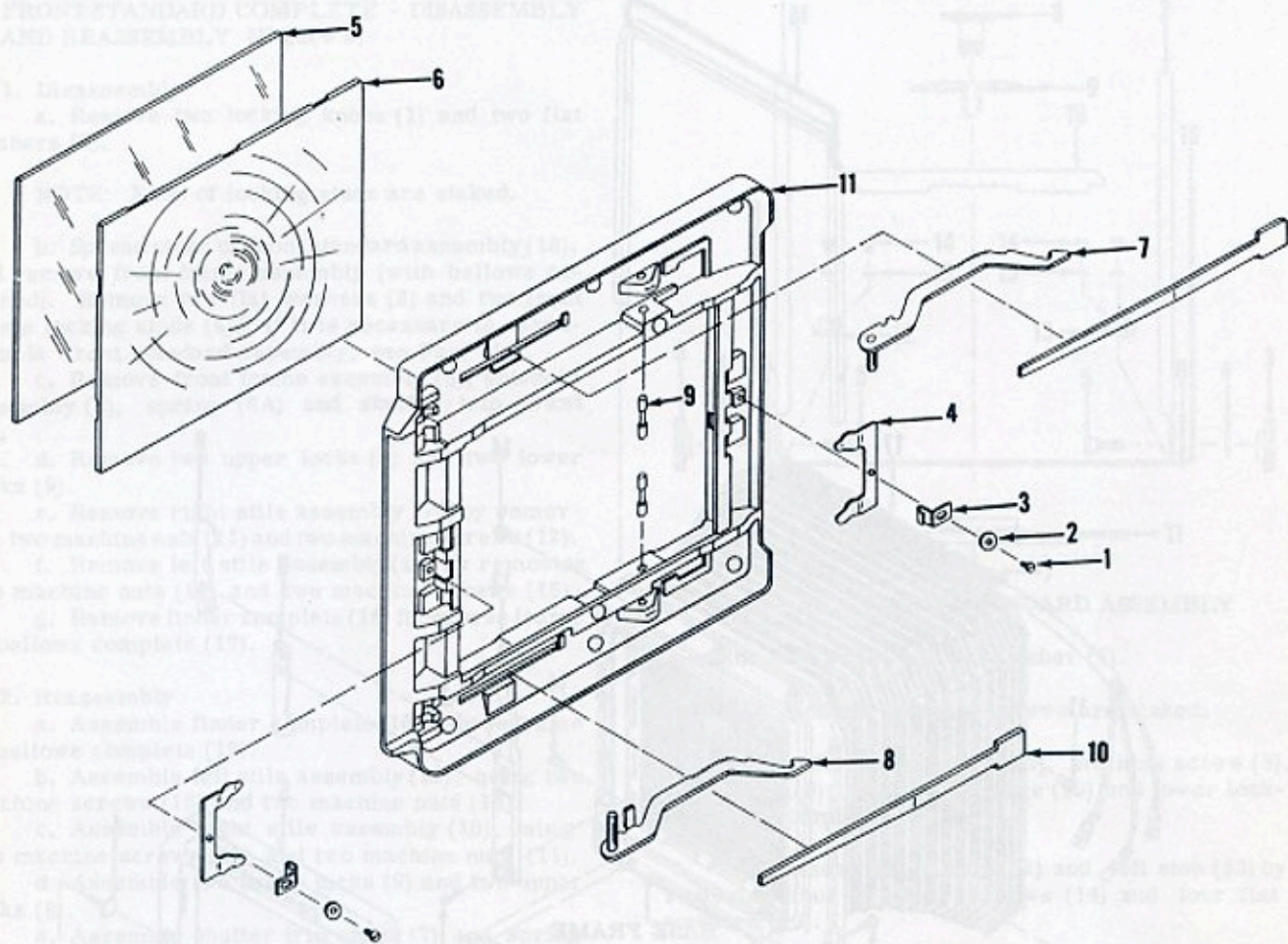

Figure 8. FOCUSING FRAME ASSEMBLY

T. FOCUSING FRAME ASSEMBLY - DISASSEMBLY AND REASSEMBLY (Figure 8)

1. Disassembly

a. Remove machine screw (1), flat washer (2), focusing hood retainer (3) and focusing screen retainer (4) on two sides.

b. Remove ground glass focusing screen (5) and Ektalite screen (6).

c. Remove arm assembly (7) or (8) by lifting upward on hook end of arm and pulling straight backward.

d. If necessary, remove spring pin (9) and arm assembly spring (10) by depressing spring (releasing spring tension on shaft of pin) and driving pin towards large opening in focusing frame (11). Repeat same procedure on opposite side.

e. Wash ground glass focusing screen (5) and Ektalite screen (6) with soap and water. Rinse thoroughly and dry.

CAUTION: Do not use cleaner containing an abrasive or solvent on either ground glass or Ektalite screen that will scratch or react to plastic.

2. Reassembly

a. If arm assembly spring (10) and spring pin (9) have been removed from focusing frame (11), locate spring in position in focusing frame, depress spring and drive pin in place.

b. Use a small tool to lift upward on tapered end of arm assembly spring (10) and assemble arm assembly (8) or (7).

NOTE: Use a tool that will not scratch or damage painted surfaces of focusing frame.

c. Assemble Ektalite screen (6) and ground glass focusing screen (5) so that the grooved side of Ektalite screen is in contact with frosted side of ground glass screen. Polished side of ground glass screen will be on the outside.

d. Assemble focusing screen retainer (4), focusing hood retainer (3), flat washer (2) and machine screw (1) on two sides.

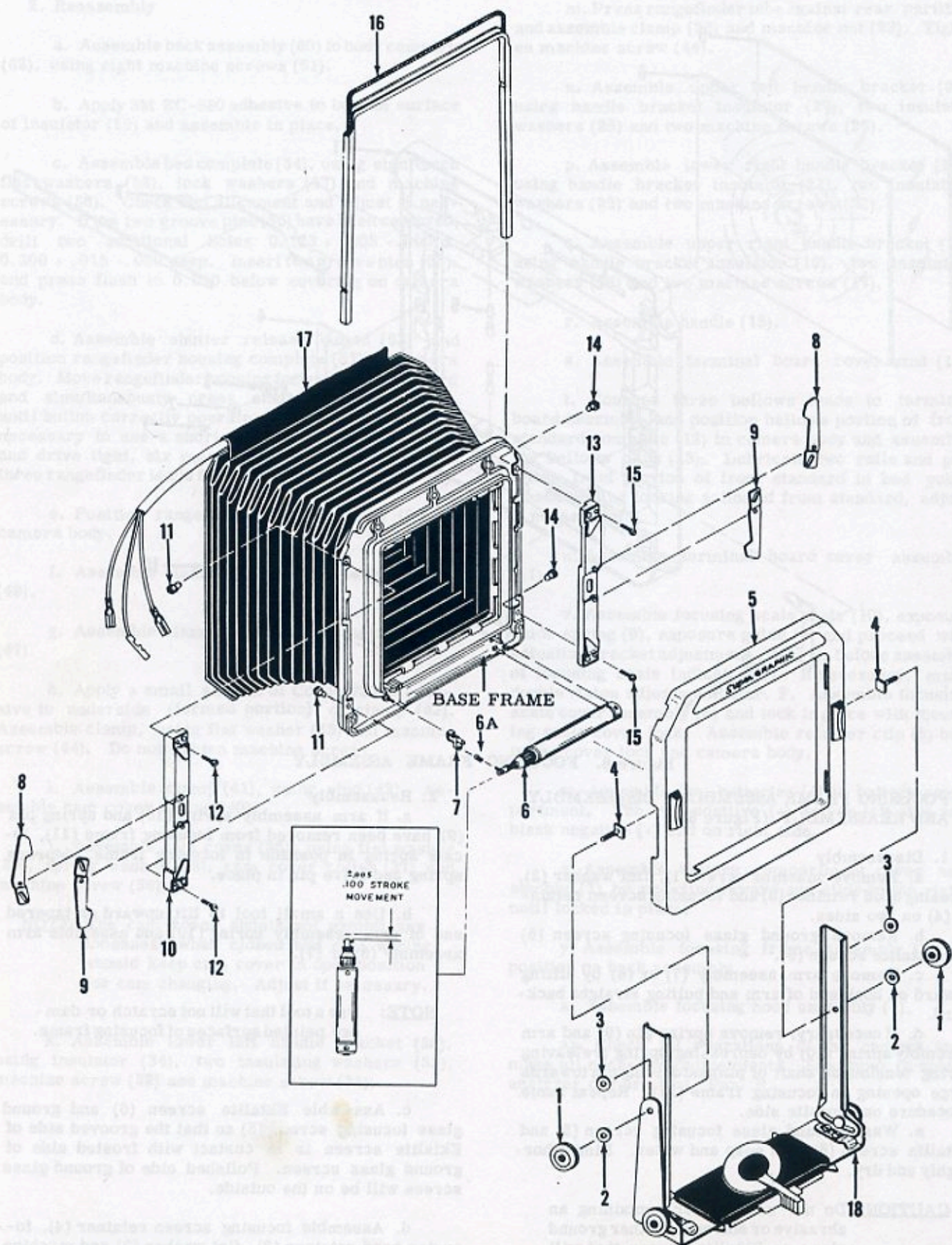

Figure 9. FRONT STANDARD COMPLETE

U. FRONT STANDARD COMPLETE - DISASSEMBLY AND REASSEMBLY (Figure 9)

1. Disassembly

a. Remove two locking knobs (1) and two flat washers (2).

NOTE: Ends of locking studs are staked.

b. Spread sides of front standard assembly (18) and remove front frame assembly (with bellows attached). Remove two flat washers (3) and two front frame locking studs (4). If it is necessary to disassemble front standard assembly, see Par. U. 1.

c. Remove front frame assembly (5), solenoid assembly (6), spring (6A) and shutter trip crank (7).

d. Remove two upper locks (8) and two lower locks (9).

e. Remove right stile assembly (10) by removing two machine nuts (11) and two machine screws (12).

f. Remove left stile assembly (13) by removing two machine nuts (14) and two machine screws (15).

g. Remove finder complete (16) from base frame of bellows complete (17).

2. Reassembly

a. Assemble finder complete (16) in base frame of bellows complete (17).

b. Assemble left stile assembly (13), using two machine screws (15) and two machine nuts (14).

c. Assemble right stile assembly (10), using two machine screws (12) and two machine nuts (11).

d. Assemble two lower locks (9) and two upper locks (8).

e. Assemble shutter trip crank (7) and spring (6A) to solenoid pin and assemble solenoid assembly (6). Assemble front frame assembly (5).

NOTE: Spring (6A) replaces washer or washers previously used to minimize forward travel of the shutter crank. The shutter crank must operate without binding.

f. Apply paraffin to two sliding surfaces of two front frame locking studs (4) and assemble studs in opening between bellows base frame and front frame assembly.

g. Spread two sides of front standard assembly (18) and assemble the above sub assembly, using flat washer (3) between front standard and supports on two sides.

h. Assemble two flat washers (2) and two locking knobs (1). Stake ends of locking studs (4).

U. 1. FRONT STANDARD ASSEMBLY - DISASSEMBLY AND REASSEMBLY (Figure 9A)

1. Disassembly

a. Remove right support (1) and left support (2) by removing locking knobs (3), flat washers (4),

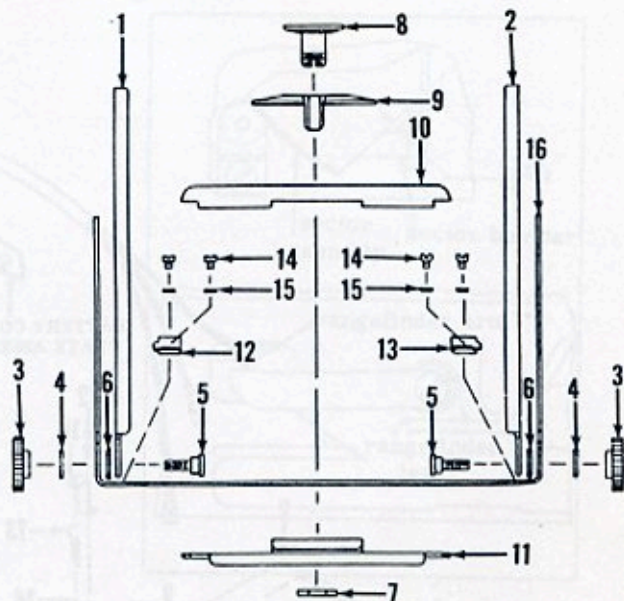

Figure 9A. FRONT STANDARD ASSEMBLY

machine screws (5) and flat washer (6).

NOTE: Ends of machine screws are staked.

b. Remove machine nut (7), machine screw (8), lock lever (9), upper lock plate (10) and lower locking plate complete (11).

c. Remove right stop (12) and left stop (13) by removing four machine screws (14) and four flat washers (15).

2. Reassembly

a. Assemble left stop (13) and right stop (12), using four flat washers (15) and four machine screws (14).

b. Assemble lower locking plate complete (11), upper lock plate (10), lock lever (9), machine screw (8) and machine nut (7).

NOTE: Before assembling lower locking plate complete (11), wipe a light coat of Dow-Corning Hi-Vac Silicone grease to sandblasted surfaces on two sides. Apply Liqui-Moly to all contacting surfaces of lock lever (9) and wipe off all visible excessive lubricant after assembly.

c. Assemble left support (2) and right support (1), using flat washers (6), special machine screws (5), flat washers (4) and locking knobs (3). Stake ends of special machine screws (5).

d. Check locking action of front standard assembly on bed yoke. If adjustment is necessary, remove machine nut (7) and turn machine screw (8) counter-clockwise to tighten or clockwise to loosen. When proper locking action has been obtained, assemble machine nut (7) and tighten.

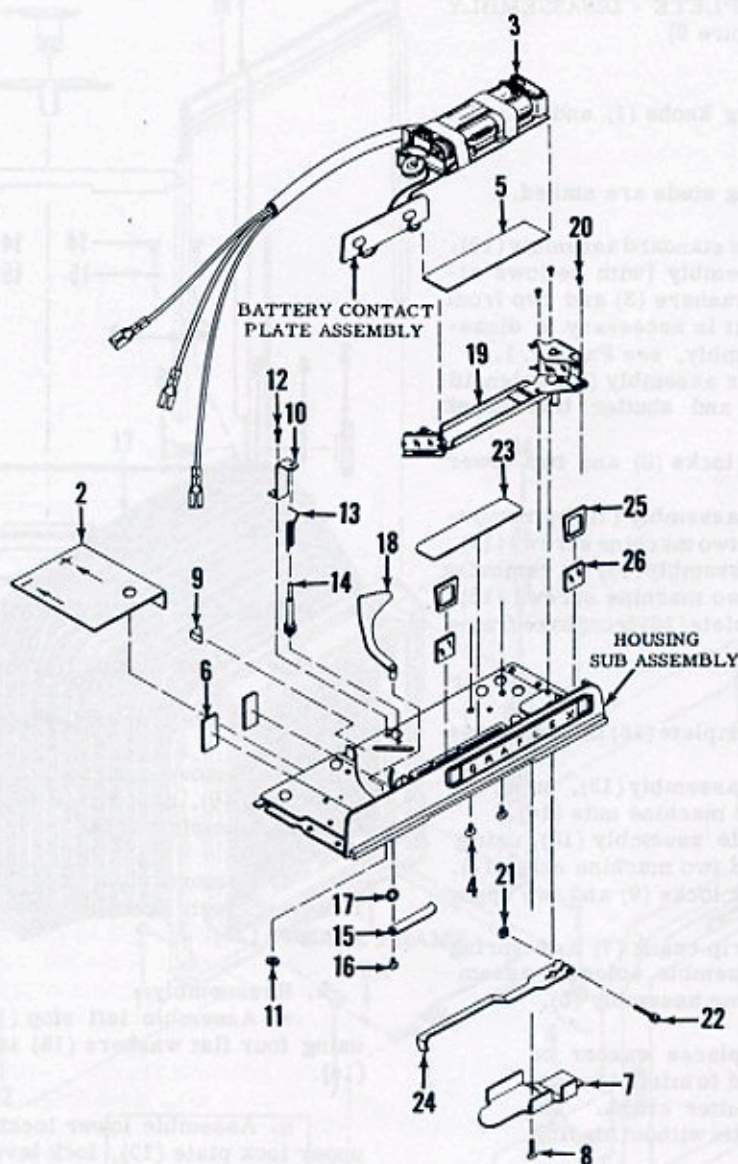

Figure 10. RANGEFINDER HOUSING COMPLETE

V. RANGEFINDER HOUSING COMPLETE - DISASSEMBLY AND REASSEMBLY (Figure 10)

1. Disassembly

- a. Remove cemented guard (2).

NOTE: Early cameras used a flat guard and a battery partition. The new designed guard, with formed side, will replace both of these items when replacement is made.

b. Remove circuit plate complete (3) by removing cemented battery contact plate assembly from housing and by removing two thread cutting screws (4). The battery contact plate is part of the circuit plate complete.

NOTE: If rangefinder housing assembly is to be returned to a Graflex Service De-

partment, do not disassemble any further. Refer to note on Parts List pages 42 or 60.

- c. Remove insulator (5).

d. If necessary, remove two cemented contact battery plate insulators (6).

e. Remove rangefinder arm shield (7) by removing machine screw (8).

f. If necessary, remove cemented sector bumper (9).

g. Remove pinion bracket (10) by removing machine nut (11) and machine screw (12).

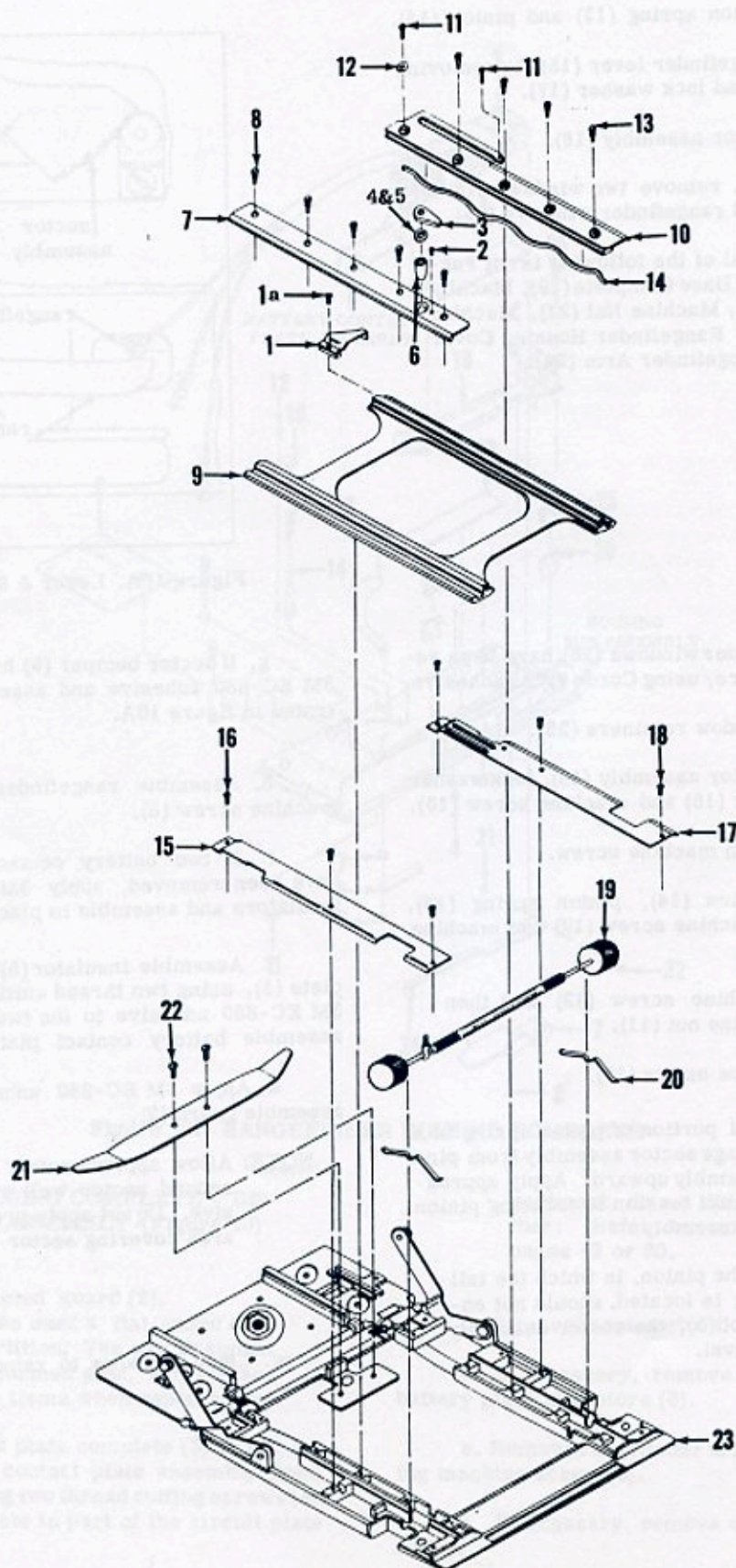

Figure 11. BED COMPLETE

W. BED COMPLETE - DISASSEMBLY AND REASSEMBLY (Figure 11)

1. Disassembly

a. Remove rangefinder actuating bracket assembly (1) by removing one machine screw (1a). The machine screw is part of the rangefinder actuating bracket assembly.

NOTE: Early rangefinder actuating bracket required a plate and two machine screws for mounting.

b. Remove machine screw (2), yoke lock lever (3), flat washers (4 or 5) and yoke lock sleeve (6).

c. Remove right yoke guide (7) by removing five machine screws (8).

d. Remove bed yoke (9).

e. Remove left yoke guide (10) by removing two machine screws (11), one machine screw (12) and four machine screws (13).

f. Remove two yoke springs (14) from underside of left yoke guide.

g. Remove right bed cover (15) by removing three machine screws (16).

h. Remove left bed cover (17) by removing three machine screws (18).

i. Remove focusing pinion assembly (19) and two focusing pinion springs (20).

j. Remove bed brace spring (21) from bed assembly (23) by removing two machine screws (22).

2. Reassembly

a. Assemble bed brace spring (21) to bed assembly (23), using two machine screws (22)

b. Apply lubricant SG 4455 or equal, to cradle portion of two focusing pinion springs (20) and to teeth of focusing pinion (19).

c. Assemble two focusing pinion springs and focusing pinion assembly in bed assembly.

d. Assemble left bed cover (17), using three machine screws (18).

e. Assemble right bed cover (15), using three machine screws (16).

f. Assemble yoke springs (14) to underside of left yoke guide (10), with straight end of springs located to the rear. Apply #107 Lubriplate or equal, to groove of left yoke guide.

g. Position left yoke guide, with spring attached, in bed assembly. Insert and start four machine screws (13). Do not tighten machine screws. Place one lock washer (12) in recess and drive in two machine screws (11).

h. Apply Mobilux No. 2 or equal, to teeth of bed yoke (9). Apply #107 Lubriplate or equal, to sliding surfaces of bed yoke and to groove of right yoke guide. (7).

i. Position bed yoke and right yoke guide in bed assembly with bed yoke located in grooves of the left and right yoke guides. Insert and start two machine screws (8) in the two front mounting holes of right yoke guide. Do not tighten machine screw.

j. Assemble yoke lock sleeve (6).

k. Rack bed yoke back and forth to equalize focusing pinion on two sides.

m. Tighten two machine screws (8).

n. Insert and drive tight, three machine screws (8). Tighten machine screws (13).

p. Assemble yoke lock lever (3) so that yoke lock lever will securely lock bed yoke within 60° clockwise movement and clear bed guide. Use flat washers (5 or 4) or any combination of these washers to obtain this adjustment.

NOTE: Excessive tightening of the yoke lock lever will prevent smooth travel of bed yoke.

When proper locking action of yoke lock lever has been accomplished, assemble and adjust machine screw (2).

q. Rack bed yoke back and forth and check bed yoke for smooth travel, adjust if necessary.

r. Assemble rangefinder actuating bracket assembly (1) to bed yoke, using machine screw (1a). See actuating bracket adjustment, Par. G.

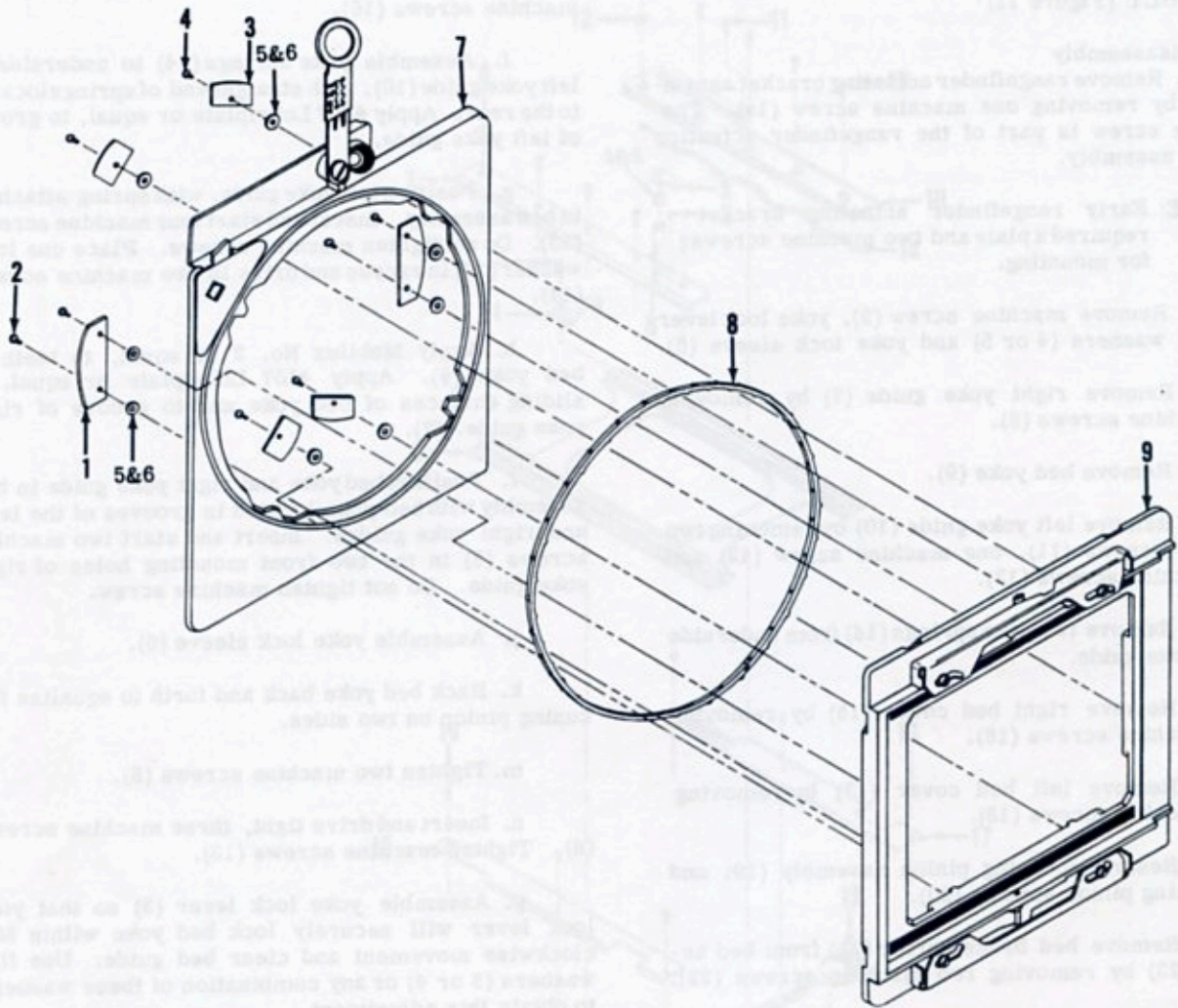

Figure 12. BACK ASSEMBLY

X. BACK ASSEMBLY - DISASSEMBLY AND REASSEMBLY (Figure 12)

1. Disassembly

a. Remove four machine screws (2), four machine screws (4), two retainers (1), four retainers (3), washers (5 & 6, used as required), and stationary frame complete (7). If disassembly of the stationary frame complete is necessary, see Par. X. 1.

b. Remove revolving ring (8) from grooved track of the revolving frame complete (9). If disassembly of the revolving frame complete is necessary, see Par. X. 2.

2. Reassembly

a. Apply Dow-Corning Hi-Vac grease on two

sides of revolving ring (8) and assemble revolving ring in grooved track of the revolving frame complete (9).

NOTE: Grease must not appear on any visible surfaces when revolving frame is rotated.

b. Position revolving frame complete, with revolving ring assembled, and stationary frame complete (7). Assemble washers (6 & 5, as required), four retainers (3), two retainers (1), four machine screws (4) and two machine screws (2).

c. Turn revolving frame several times to insure proper seating of revolving ring. The revolving frame must fit snug and turn without binding.

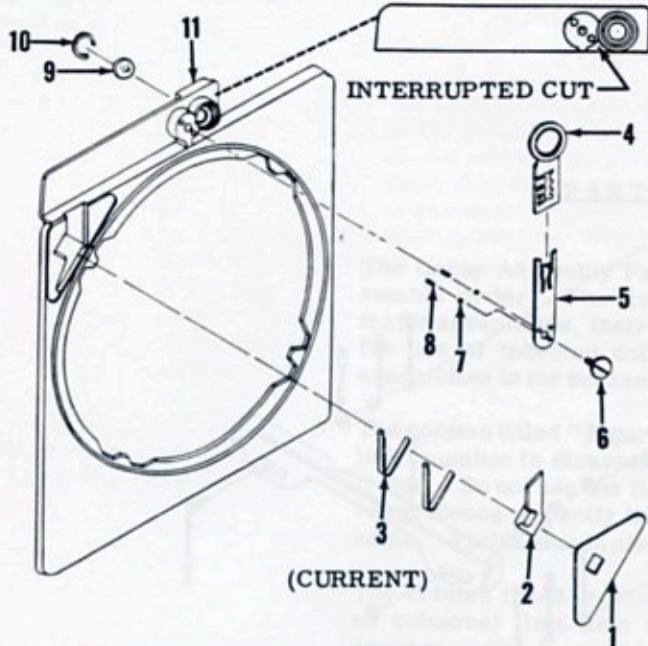

Figure 12A. STATIONARY FRAME COMPLETE

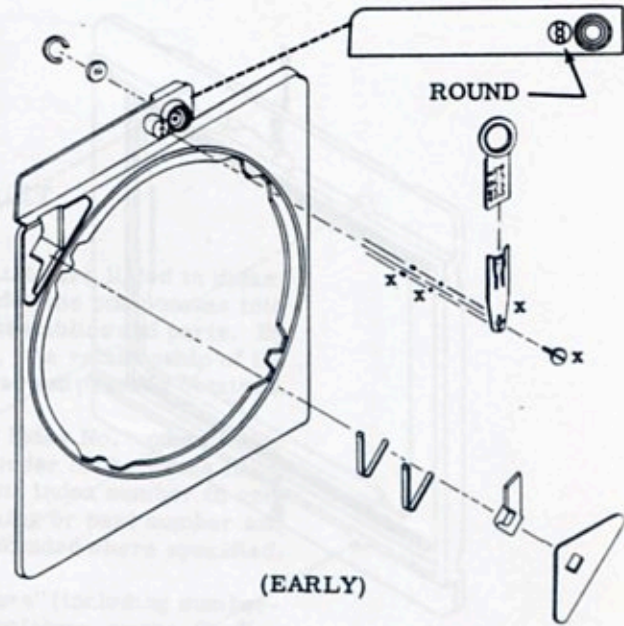

Figure 12B. STATIONARY FRAME COMPLETE

NOTE: A change has been made on the stationary frame as illustrated in figures 12, 12A & 12B. Disassembly and reassembly procedures remain the same. Items marked x in figure 12B are not interchangeable with corresponding items in figure 12A. When ordering replacement parts, refer to the correct parts list.

X. 1. STATIONARY FRAME COMPLETE - DISASSEMBLY AND REASSEMBLY (Figure 12A)

1. Disassembly

a. Remove cemented release button cover (1). Remove release button (2) and two button springs (3) from cavity in stationary frame.

b. Remove peepsight assembly (4).

c. Remove peepsight carrier (5) by removing machine screw (6), two steel balls (7) and two carrier springs (8).

d. Remove rear window (9) from stationary frame assembly (11) by removing retaining ring (10).

2. Reassembly

a. Assemble rear window (9) and retaining ring (10) in stationary frame assembly (11).

b. Insert two carrier springs (8) into two small holes in boss of stationary frame for carrier peepsight mounting. Apply a light coat of Dow-Corning #44 Silicone grease to two steel balls (7) and place a ball over each carrier spring. Apply paraffin to two sides of peepsight carrier (5) and apply Neolube to underside of head of machine screw (6). Position peepsight carrier in place and secure with machine screw.

c. Assemble peepsight assembly (4) to peepsight carrier.

d. Assemble two button springs (3) in cavity of stationary frame. Apply a light coat of Dow-Corning #44 Silicone grease to release button (2) and position in place. Apply 3M 776 adhesive to area around cavity opening in stationary frame, keeping within .050 in. from edges of cavity. Assemble release button cover (1) and remove excess adhesive.

e. Check release button, peepsight assembly and carrier peepsight for smooth operation.

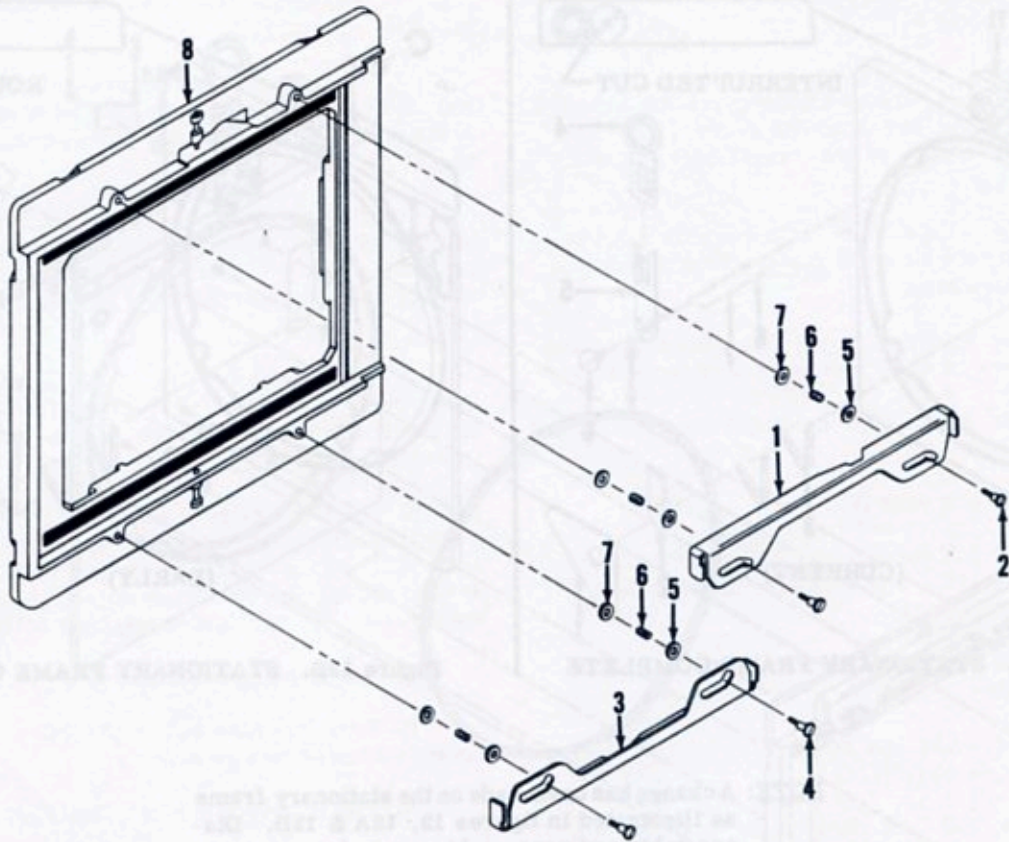

Figure 12C. REVOLVING FRAME COMPLETE

X. 2. REVOLVING FRAME COMPLETE - DISASSEMBLY AND REASSEMBLY (Figure 12C)

1. Disassembly

a. Remove two machine screws (2), upper slide lock (1), and two each flat washers (5), slide lock springs (6) and flat washers (7).

b. Remove two machine screws (4), lower slide lock (3), and two each flat washers (5), slide lock springs (6) and flat washers (7) from frame assembly

(8).

2. Reassembly

a. To frame assembly (8), assemble two flat washers (7), two slide lock springs (6), two flat washers (5), lower slide lock (3) and two machine screws (4).

b. Assemble two flat washers (7), two slide lock springs (6), two flat washers (5), upper slide lock (1) and two machine screws (2).